

## **Supplemental COVID Face Shield - Instructions for Use**

These instructions for use correspond to V3 of the **DtM COVID-19 Face Shield**. The revision of the corresponding shield can be found on the inside edge of the shield.

### **Appropriate Use Criteria**

This supplementary face shield was created as an emergency action in effort to protect people by providing backup Personal Protective Equipment (PPE) options if the standard PPE has become unavailable. This device has not gone through the same regulatory approval process as standard PPE but has gone through a special verification process expedited strictly for the response to the COVID-19 pandemic.

The use of this supplementary face shield should always come secondary to existing PPE equipment, standards, and protocol options if available. The decision to implement this device should be made with careful consideration and under the consultation of the corresponding institution's occupational health and infection control departments.

The information included in this document provides device description and feature overview as well as recommended assembly steps and cleaning instructions for reuse.

## Device Overview

This supplementary face shield consists of three (3) components: the shield, the cradle, and an adjustable elastic strap. A diagram of the components is shown below in **Fig. 1**.

This face shield is designed to receive a standard 8.5" x 11" report cover (or similar transparency sheet) that can be attached and secured by using the three-hole geometry found in a standard punch. The clear plastic face shield and the 3D printed (or cast) cradle can be disinfected using common disinfecting solutions and reused. See **Appendix A** for disinfecting solutions recommended for this device. This device can utilize various shield materials to accommodate for variation in supply chain access. See **Appendix B** for guidelines on recommended material selection.

Components disposed of after daily use or potential Blood Borne Pathogens (BBP) exposure:

- Elastic Strap

Components to be disinfected and reused as long as proper disinfectant protocol is followed and there is no visible damage to parts:

- 3D printed (or cast) Cradle
- Clear plastic shield

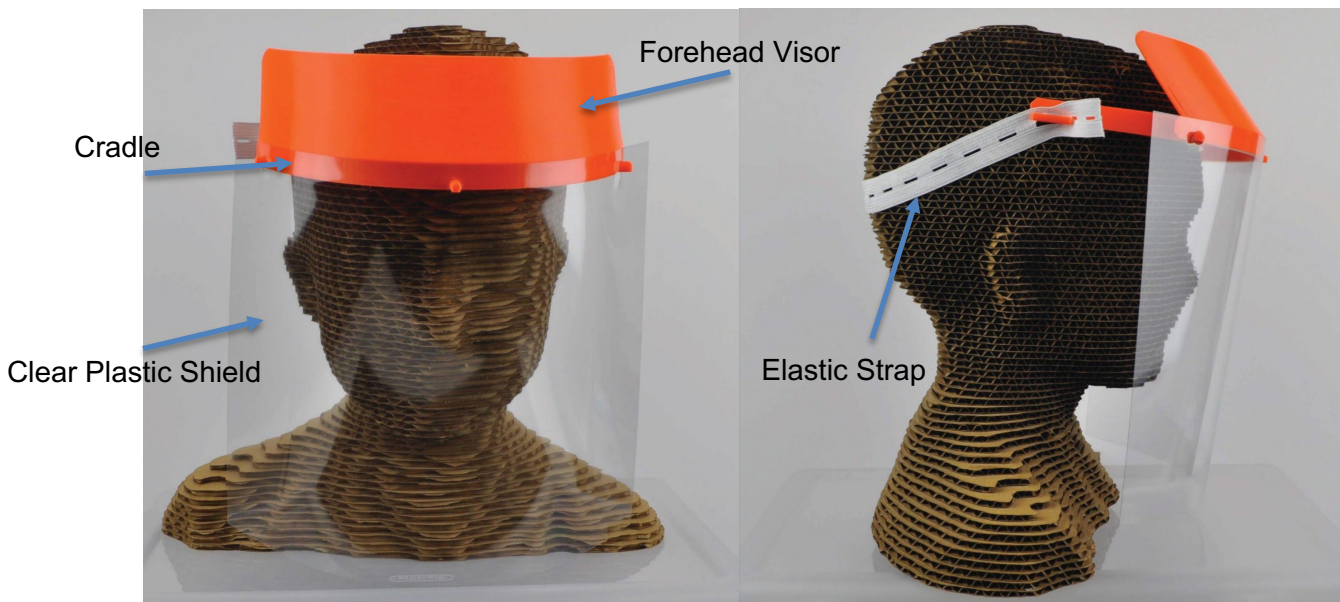

Fig. 1

# Point of Care Assembly and Cleaning Instructions

For properly assembling the supplemental face shield, please refer to the instructions outlined below.

## Assembly Steps

1. Find a clean disinfected environment to work in.
2. Don a pair of clean gloves.
3. We recommend following a standard disinfecting protocol as outlined in **Recommended Cleaning** prior to first assembly
4. Take a single Cradle and Identify the flat face, this will indicate the bottom of the Cradle (label "a" in **Fig. 2**).
5. (Optional) Place a strip of micro-foam surgical tape on the inside edge of the Cradle (label "d" in **Fig. 2**) to increase comfort while wearing the face shield.
6. Take one elastic strap and slide it through the two attachment posts on either side of the Cradle positioning it one hole in from the edge of the elastic strap (label "b" in **Fig. 2**).
7. Holding the Cradle in your non-dominant hand, secure one of the outer holes in the Shield to the Cradle peg (label "c" in **Fig. 2**). Pull the Shield across the Cradle so that the middle and remaining edge holes line up with the pegs on the Cradle. The shield should gently snap into place.
8. (Optional) Place a piece of tape over the 3 mounting holes/pegs in the face shield to fully seal any remaining gaps.
9. Turn the face shield so the front is facing the ground and hold it by the forehead visor. Gently shake the face shield to ensure that the shield is securely fastened and will not fall off during use.
10. Do a final inspection of the mask with all components assembled to ensure nothing is damaged and everything has been assembled properly as shown in **Fig. 1** above.

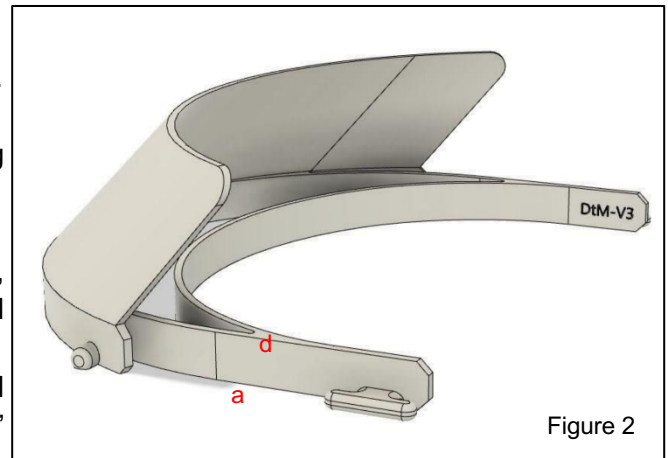

Figure 2

## Donning the Supplementary Face Shield

[Follow CDC guidelines for how to don a face shield. \(https://www.cdc.gov/vhf/ebola/hcp/ppe-training/n95respirator\\_gown/donning\\_13.html\)](https://www.cdc.gov/vhf/ebola/hcp/ppe-training/n95respirator_gown/donning_13.html)

## Doffing the Supplementary Face Shield

[Follow CDC guidelines for how to remove a contaminated face shield. \(https://www.cdc.gov/vhf/ebola/hcp/ppe-training/n95respirator\\_coveralls/doffing\\_08.html\)](https://www.cdc.gov/vhf/ebola/hcp/ppe-training/n95respirator_coveralls/doffing_08.html)

## Recommended Cleaning

These cleaning steps are performed after each user is finished needing the PPE or device has become obviously contaminated. If device is obviously contaminated remove immediately and replace with a new device while following procedure to disinfect the contaminated one. Follow the proper procedures for doffing the device.

1. Perform hand hygiene procedures and don a pair of clean gloves.
2. Remove and properly dispose of the elastic strap and shield if exposed.
3. Remove the Shield from the Cradle.
4. Using one of the recommended disinfecting products from the list outlined in **Appendix A**, prepare to perform steps 5-9 to disinfect the face shield.
5. Wipe down and disinfect the all faces and features on the Cradle.
6. Wipe down and disinfect both sides of the clear plastic Shield.
7. Doff gloves, perform hand hygiene procedures, and don a new pair of gloves
8. Wipe down the entire face shield again making sure to cover all surfaces of the face shield (inside and outside) one more time.
9. Ensure the surface is visibly wet with the disinfectant product for the duration of the contact time as defined by the [EPA guidelines in List N: Disinfectants for Use Against SARS-CoV-2 \(https://www.epa.gov/pesticide-registration/list-n-disinfectants-use-against-sars-cov-2\)](https://www.epa.gov/pesticide-registration/list-n-disinfectants-use-against-sars-cov-2).
10. Wipe any excess disinfectant and dry the face shield using a clean paper towel

## Preparing the Supplementary Face Shield for Reuse.

1. Once the face shield is dry, follow the assembly steps listed above for assembly of a new face shield.

## Appendix A: Recommended Disinfectants

From FDA guidelines on [Enforcement Policy for Sterilizers, Disinfectant Devices, and Air Purifiers During the Coronavirus Disease 2019 \(COVID-19\) Public Health Emergency](https://www.fda.gov/regulatory-information/search-fda-guidance-documents/enforcement-policy-sterilizers-disinfectant-devices-and-air-purifiers-during-coronavirus-disease?utm_campaign=2020-03-29%20FDA%20Issues%20New%20Enforcement%20Policy%20for%20Sterilizers&utm_medium=email&utm_source=Eloqua) released March 2020 ([https://www.fda.gov/regulatory-information/search-fda-guidance-documents/enforcement-policy-sterilizers-disinfectant-devices-and-air-purifiers-during-coronavirus-disease?utm\\_campaign=2020-03-29%20FDA%20Issues%20New%20Enforcement%20Policy%20for%20Sterilizers&utm\\_medium=email&utm\\_source=Eloqua](https://www.fda.gov/regulatory-information/search-fda-guidance-documents/enforcement-policy-sterilizers-disinfectant-devices-and-air-purifiers-during-coronavirus-disease?utm_campaign=2020-03-29%20FDA%20Issues%20New%20Enforcement%20Policy%20for%20Sterilizers&utm_medium=email&utm_source=Eloqua)) it is recommended that “this policy is intended to remain in effect only for the duration of the public health emergency related to COVID-19 declared by the Department of Health and Human Services (HHS), including any renewals made by the HHS Secretary in accordance with section 319(a)(2) of the Public Health Service Act (PHS Act)”. The policy recommends to use an approved disinfection agent as it should “minimize the viability of SARS-CoV-2” on the surface of a Cradle and Shield.

From the [EPA guidelines in List N: Disinfectants for Use Against SARS-CoV-2](https://www.epa.gov/pesticide-registration/list-n-disinfectants-use-against-sars-cov-2) (<https://www.epa.gov/pesticide-registration/list-n-disinfectants-use-against-sars-cov-2>) and [American Chemistry list of Novel Coronavirus \(COVID-19\)—Fighting Products the](https://www.americanchemistry.com/Novel-Coronavirus-Fighting-Products-List.pdf) (<https://www.americanchemistry.com/Novel-Coronavirus-Fighting-Products-List.pdf>), based on the informal testing done, it is recommended to use the following four solutions for the disinfecting procedures of the face shield. Other disinfectants may work as well but have not been evaluated. Note: the following list is in preferential order and have been tested with this device.

1. Super Sani-Cloth
2. 10% chlorine bleach solution (\*May fog Shield over time)
3. CaviWipes
4. Soap and water

## Appendix B: Recommended Shield Materials

The level of protection provided by the supplementary face shield will be determined in part by the Shield material used. The following list is in preferential order and have been tested with this device. Other readily available materials may be suitable as a replacement but have not been tested and should be used as a last resort.

1. GBC ClearView Presentation Covers (P/n: GBC 2000041)
2. Avery (P/n: 16741)
3. Highland Transparency Film 901 (P/n: 78-6969-8594-0)
4. Corporate Express Transparency Film (P/n: CEB00560)

## Appendix C: Materials in Direct Contact with Skin

Two components will be in direct contact with the provider's skin; the Cradle, and the Elastic Strap. The device also allows for a strip of micro-foam surgical tape to be placed on the inside of the Cradle to increase the level of comfort provided to the user.

**Cradle Material(s):** Material selection will be subject to availability at each printing location. PLA is recommended for 3D printing as it is widely available and can be printed on most 3D printers.

### 3D Printed

- PLA (Polylactic Acid)
- ABS (Acrylonitrile butadiene styrene)
- PETG (Polyethylene Terephthalate Glycol-modified)
- Nylon

### Cast

Smooth-On Smooth-Cast ([SDS - https://www.smooth-on.com/tb/files/SMOOTHCAST\\_SEMI-RIGIDS\\_TB.pdf](https://www.smooth-on.com/tb/files/SMOOTHCAST_SEMI-RIGIDS_TB.pdf))

### **Elastic Strap Material(s):**

- Polyester/Nylon blend